

# Hazardous Duty Power Pushers™

Battery-Powered Material  
Handling Equipment



The **Hazardous Duty Power Pushers™** certified for Class 1, Division 1, Group D areas, are designed to tackle challenging applications in demanding environments. With a temperature classification rating of T4, they can withstand temperatures reaching 135°C. With two models, the Hazardous Duty Power Pushers can push or pull carts, trollies, vats and more, weighing up to 150,000 pounds. Plus, with a wide variety of application-specific attachments available, they can be customized to your requirements for a high-quality, heavy-duty tug for challenging environments.

# Hazardous Duty Power Pushers™

## FEATURES AND BENEFITS

- 24-Volt DC, 400-watt motor for powerful push/pull capacity of 25,000 pounds
- 36-Volt DC, 1500-watt motor provides 150,000 pounds of push/pull capacity
- Class 1, Division 1, Group D certified for use in hazardous locations
- T4 temperature classification for operation in 135°C
- Rechargeable, fully sealed gel cell marine batteries for long operational life
- Fully programmable control system with diagnostic features to adjust speed and acceleration/ deceleration based on load and environment
- Ergonomic handles and hand guards for operator comfort and safety

## OPTIONS

- Strobe and audible motion beeper for safety and visibility on plant floor
- Versatile standard and custom attachment options available - see website

## SPECIFICATIONS

- **Motor types:** 24 Volt D.C. 400 W  
36 Volt D.C. 1500 W
- **Gearbox:** Single speed reduction gearbox, with differential
- **Drive Mechanism:** 2 x chain and sprocket
- **Controller:** Fully programmable, with diagnostic capability
- **Batteries:** Sealed, gel cell marine batteries
- **Battery Charger:** Stand-alone, 3 stage, 2 x 10 Amp circuits
- **Push/Pull Capacity:** Up to 25,000 lbs. for 24 Volt D.C. 400 W (subject to rolling resistance of load)  
Up to 150,000 lbs. for the 36 Volt D.C. 1500 W (subject to rolling resistance of load)

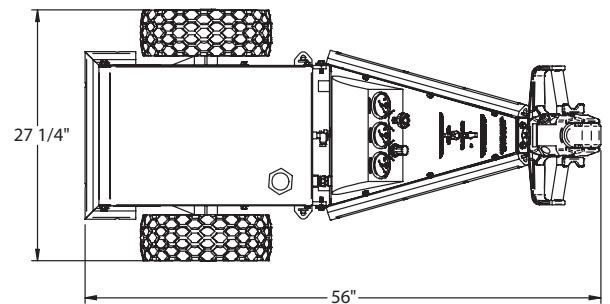
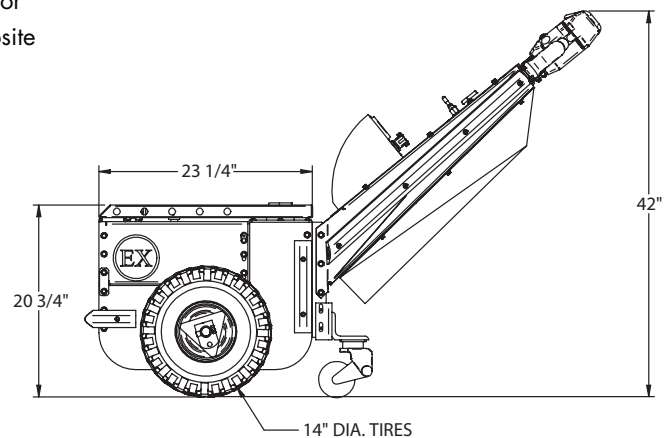

(Dimensions above are the standard Hazardous Duty Power Pusher)



1425 Stagecoach Road, Shakopee, MN 55379  
Phone: 800.800.9274 or 952.445.8295  
Fax: 952.445.0231

[powerpusher.com](http://powerpusher.com)

